

**Boost chopper
Trench IGBT® Power Module**

**$V_{CES} = 1200V$
 $I_C = 35A @ T_c = 80^\circ C$**

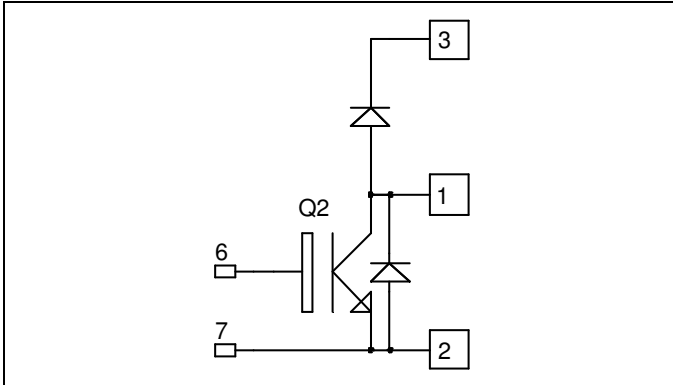

Application

- AC and DC motor control
- Switched Mode Power Supplies
- Power Factor Correction

Features

- Trench + Field Stop IGBT® Technology
 - Low voltage drop
 - Low tail current
 - Switching frequency up to 20 kHz
 - Soft recovery parallel diodes
 - Low diode VF
 - Low leakage current
 - Avalanche energy rated
 - RBSOA and SCSOA rated
- Kelvin emitter for easy drive
- Low stray inductance
 - M5 power connectors
- High level of integration

Benefits

- Outstanding performance at high frequency operation
- Stable temperature behavior
- Very rugged
- Direct mounting to heatsink (isolated package)
- Low junction to case thermal resistance
- Easy paralleling due to positive TC of VCEsat

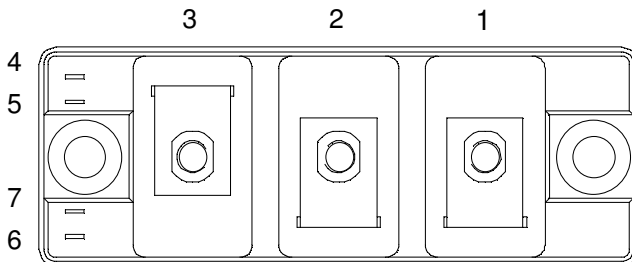

Absolute maximum ratings

| Symbol | Parameter | Max ratings | Unit |
|-----------|---------------------------------------|---------------------|-----------|
| V_{CES} | Collector - Emitter Breakdown Voltage | 1200 | V |
| I_C | Continuous Collector Current | $T_C = 25^\circ C$ | 55 |
| | | $T_C = 80^\circ C$ | 35 |
| I_{CM} | Pulsed Collector Current | $T_C = 25^\circ C$ | 70 |
| V_{GE} | Gate - Emitter Voltage | ± 20 | V |
| P_D | Maximum Power Dissipation | $T_C = 25^\circ C$ | 205 |
| RBSOA | Reverse Bias Safe Operation Area | $T_j = 125^\circ C$ | 70A@1200V |

CAUTION: These Devices are sensitive to Electrostatic Discharge. Proper Handling Procedures Should Be Followed.

All ratings @ $T_j = 25^\circ\text{C}$ unless otherwise specified

Electrical Characteristics

| Symbol | Characteristic | Test Conditions | Min | Typ | Max | Unit |
|--------------|---------------------------------------|--------------------------------|------|---|-----|------|
| BV_{CES} | Collector - Emitter Breakdown Voltage | $V_{GE} = 0V, I_C = 1.5mA$ | 1200 | | | V |
| I_{CES} | Zero Gate Voltage Collector Current | $V_{GE} = 0V, V_{CE} = 1200V$ | | | 5 | mA |
| $V_{CE(on)}$ | Collector Emitter on Voltage | $V_{GE} = 15V$ $I_C = 35A$ | | $T_j = 25^\circ\text{C}$ 1.7 $T_j = 125^\circ\text{C}$ 2.0 | 2.1 | V |
| $V_{GE(th)}$ | Gate Threshold Voltage | $V_{GE} = V_{CE}, I_C = 1.5mA$ | 5.0 | 5.8 | 6.5 | V |
| I_{GES} | Gate - Emitter Leakage Current | $V_{GE} = 20V, V_{CE} = 0V$ | | | 400 | nA |

Dynamic Characteristics

| Symbol | Characteristic | Test Conditions | Min | Typ | Max | Unit |
|--------------|------------------------------|--|-----|-----|-----|------|
| C_{ies} | Input Capacitance | $V_{GE} = 0V, V_{CE} = 25V$ | | 2.5 | | nF |
| C_{res} | Reverse Transfer Capacitance | $f = 1MHz$ | | 0.1 | | |
| $T_{d(on)}$ | Turn-on Delay Time | Inductive Switching (25°C) $V_{GE} = \pm 15V$ $V_{Bus} = 600V$ $I_C = 35A$ $R_G = 27\Omega$ | | 150 | | ns |
| T_r | Rise Time | | | 90 | | |
| $T_{d(off)}$ | Turn-off Delay Time | | | 550 | | |
| T_f | Fall Time | | | 130 | | |
| $T_{d(on)}$ | Turn-on Delay Time | Inductive Switching (125°C) $V_{GE} = \pm 15V$ $V_{Bus} = 600V$ $I_C = 35A$ $R_G = 27\Omega$ | | 180 | | ns |
| T_r | Rise Time | | | 100 | | |
| $T_{d(off)}$ | Turn-off Delay Time | | | 650 | | |
| T_f | Fall Time | | | 180 | | |

Reverse diode ratings and characteristics

| Symbol | Characteristic | Test Conditions | Min | Typ | Max | Unit |
|-----------|-------------------------|---|-----|---|-----|---------|
| V_F | Diode Forward Voltage | $I_F = 35A$ $V_{GE} = 0V$ | | $T_j = 25^\circ\text{C}$ 1.6 $T_j = 125^\circ\text{C}$ 1.6 | 2.1 | V |
| E_{rec} | Reverse Recovery Energy | $I_F = 35A$ $V_R = 600V$ $di/dt = 990A/\mu s$ | | $T_j = 125^\circ\text{C}$ 2.7 | | mJ |
| Q_{rr} | Reverse Recovery Charge | $I_F = 35A$ $V_R = 600V$ $di/dt = 990A/\mu s$ | | $T_j = 25^\circ\text{C}$ 3.7 $T_j = 125^\circ\text{C}$ 6.8 | | μC |

Thermal and package characteristics

| Symbol | Characteristic | Min | Typ | Max | Unit | |
|------------|---|---------------|-----|-----|------------------|--------------------|
| R_{thJC} | Junction to Case | IGBT | | | 0.6 | $^\circ\text{C}/W$ |
| | | Diode | | | 0.95 | |
| V_{ISOL} | RMS Isolation Voltage, any terminal to case $t = 1$ min, $I_{isol} < 1mA, 50/60Hz$ | 2500 | | | V | |
| T_j | Operating junction temperature range | -40 | | 150 | $^\circ\text{C}$ | |
| T_{STG} | Storage Temperature Range | -40 | | 125 | | |
| T_C | Operating Case Temperature | -40 | | 125 | | |
| Torque | Mounting torque | For terminals | M5 | 2 | 3.5 | N.m |
| | | To Heatsink | M6 | 3 | 5 | |
| Wt | Package Weight | | | | 180 | g |

Package outline

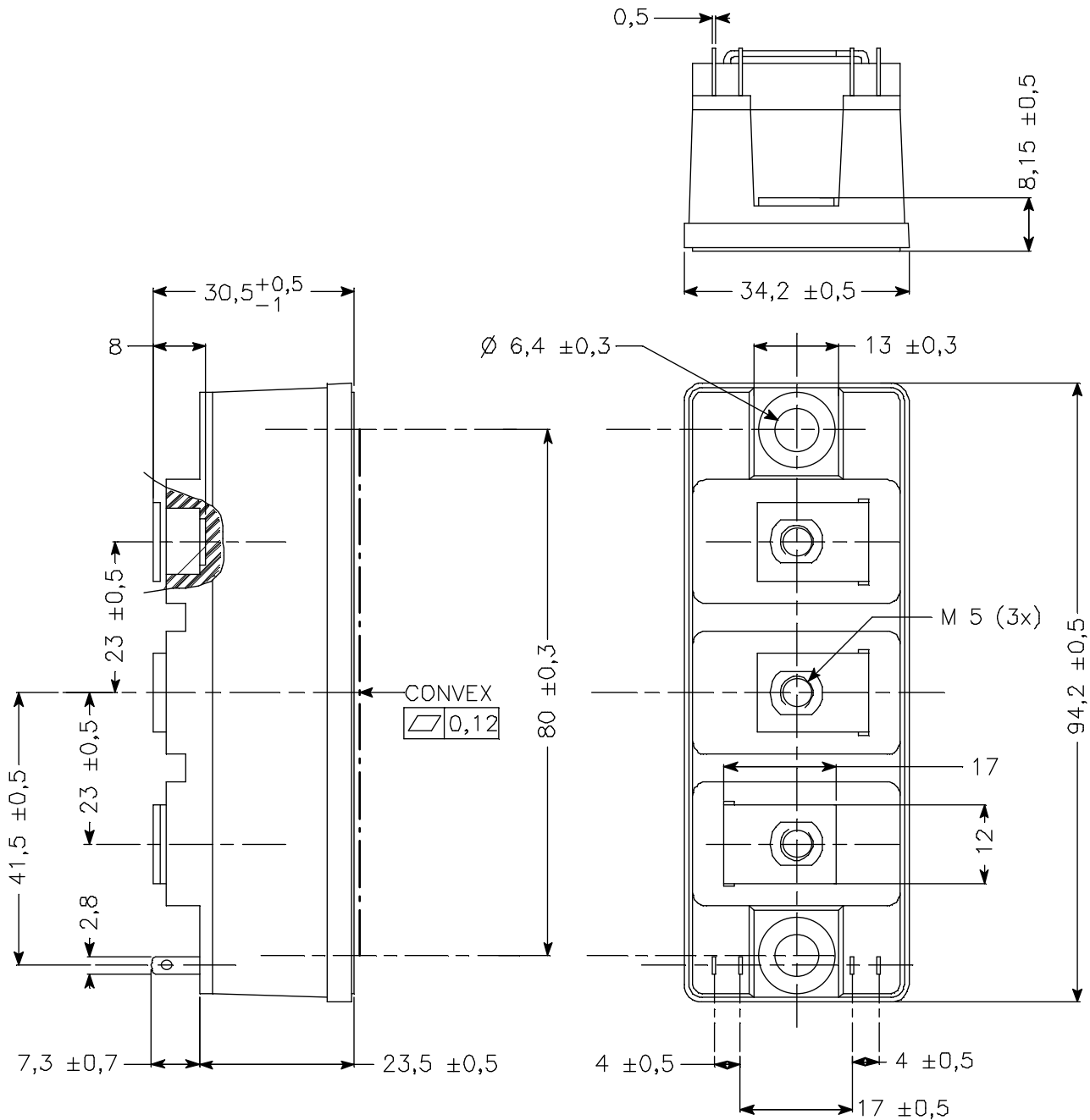

APT reserves the right to change, without notice, the specifications and information contained herein

APT's products are covered by one or more of U.S patents 4,895,810 5,045,903 5,089,434 5,182,234 5,019,522 5,262,336 6,503,786 5,256,583 4,748,103 5,283,202 5,231,474 5,434,095 5,528,058 and foreign patents. U.S and Foreign patents pending. All Rights Reserved.